

C.I.P.

460 S&W Mag

Country of Origin: US

TAB. IV

Date 06-05-16

Revision 08-04-15

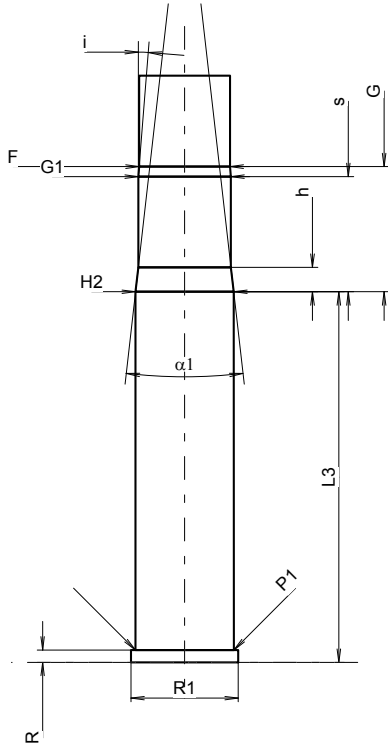
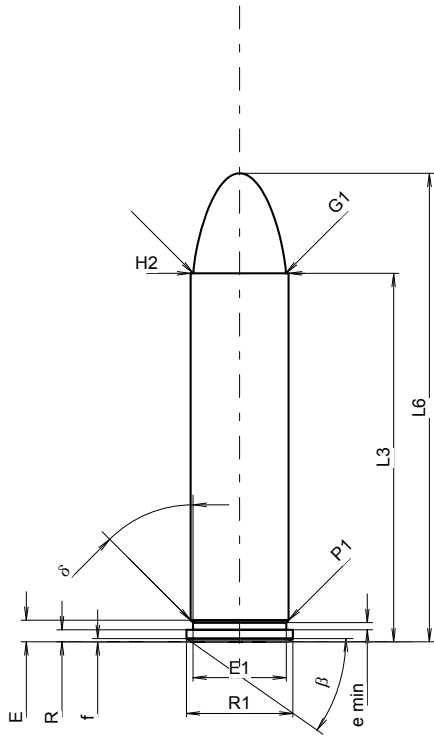

Scale 1.07:1

CARTRIDGE MAXI

Lengths

L1	=	
L2	=	
L3 ¹⁾	=	45.72
L4	=	
L5	=	
L6	=	58.12

Case Head

R ¹⁾	=	1.50	-0.25
R1	=	13.21	
R3	=		
E	=	2.68	
E1	=	11.56	
e min	=	0.89	
delta	=	45°	
f	=	0.41	
beta	=	35°	

Powder Chamber

P1	=	12.14
P2	=	

Junction Cone

alpha	=	
S	=	
r1 min	=	
r2	=	

Collar

H1	=	
H2 ¹⁾	=	12.14

Projectile

G1 ¹⁾	=	11.49
G2	=	
F	=	
L3+G ¹⁾	=	61.24

Pressures (Energies)

Method Transducer

Pmax	=	3950 bar
PK	=	4543 bar
PE	=	5135 bar
M	=	25.00

Miscellaneous Dimensions

Fe ¹⁾⁴⁾	=	0.25
delta L	=	

CHAMBER MINI

Lengths

L1	=	
L2	=	
L3 ¹⁾	=	45.97

Breech

R ¹⁾	=	1.52
R1	=	13.31
R2	=	
R3	=	
r	=	

Powder Chamber

E	=	
P1 ¹⁾	=	12.19
P2	=	

Junction Cone

alpha	=	
S	=	
r1 max	=	
r2	=	

Collar

H1	=	
H2 ¹⁾	=	12.17

Commencement of Rifling

G1 ¹⁾ *	=	11.48
G ¹⁾	=	15.52
alpha 1 *	=	13°
h	=	3.03
s *	=	14.27
i ¹⁾ *	=	4°35'
w	=	

Barrel

F ¹⁾ *	=	11.28
Z ¹⁾	=	11.46

Grooves

b	=	3.66
N	=	5
u	=	508.00
Q	=	101.61 mm ²

Notes: 1) Check for safety reasons
4) Headspace on Rim
* Basic dimensions

Dimensions in << mm >>
Dimensions and Tolerances for Proof Barrels
see Appendix CR 1.